

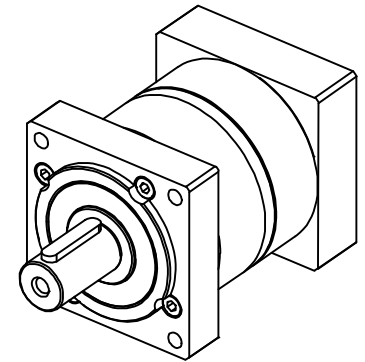

SPECIFICATIONS

Stage	1			
Gear Ratio	i	3:1	5:1	10:1
Rated Output Torque	Nm	102	138	60
Moment of Inertia	g-cm ²	800	500	400
Torsional Stiffness	Nm/arcmin	8.0		
Max output Torque	Nm	2.5 times of Rated Outout Torque		
Max radial load	N	2450		
Max axial load	N	2200		
Max input speed	RPM	8000		
Backlash	acrmin	≤ 12 (standard) ≤ 6 (precision)		
Noise level	dB(A)	≤ 64		
Operating temp.	°C	-25~90		
Lifetime	Hrs	20000		
Efficiency	%	≥ 96		
Protection Level		IP64		
Mounting Position		Any		
Weight	Kg	3.2		
Tightening Clamp Torque	N.m/in-lbs	7.94/70.30		

NOTES:

Unless Otherwise Specified
 All Angles $\pm 0.5^\circ$
 Break All Edges 0.2mm-0.8mm
 Decimals .X ± 0.2 / .XX ± 0.05
 T.I.R $\square 0.05$ $\square 0.05$ $\square 0.05$



Unit: mm	Technical reference Scale: 1:1.5	Approved by	
		Document type	Document status
		Title	
MPS90-XXX-15-S80-19		GEARBOX	
		Rev.	Date of issue
		Sheet	